



# International Journal of Engineering Research and Science & Technology

ISSN : 2319-5991  
Vol. 4, No. 2  
May 2015



[www.ijerst.com](http://www.ijerst.com)

Email: [editorijerst@gmail.com](mailto:editorijerst@gmail.com) or [editor@ijerst.com](mailto:editor@ijerst.com)

Research Paper

# AN EFFICIENT ADAPTIVE FILTER WITH LOW ADAPTATION DELAY USING LEAST MEAN SQUARE ALGORITHM

R Shofia Preethi<sup>1\*</sup> and T Jayachandran<sup>1</sup>

\*Corresponding Author: **R Shofia Preethi** ✉ [shofiaselvi@gmail.com](mailto:shofiaselvi@gmail.com)

Adaptive filtering is a wide area of researcher in present decade in the field of communication. The LMS algorithm is the most popular method for adapting a filter. The Least Mean Square adaptive filter is used here to reduce area-delay product, power-delay product and this paper also deals with cancellation of noise on speech signal using Least Mean Square (LMS) algorithm. As received signal is continuously corrupted by noise where both received signal and noise signal both changes continuously, then this arise the need of adaptive filtering.

**Keywords:** Adaptive filtering, Least Mean Square (LMS) algorithm, Noise cancellation

## INTRODUCTION

Adaptive digital filters find wide application in several digital signal processing (DSP) areas, e.g., noise and echo cancellation, system identification, channel estimation, channel equalization, etc. The LMS adaptive filter is popular not only due to its low-complexity, but also due to its stability and satisfactory convergence performance. Due to its several important applications of current relevance and increasing constraints on area, time, and power complexity, efficient implementation of the LMS adaptive filter is still quite important. To implement the LMS algorithm, one has to update the filter weights during each sampling period using the estimated error, which equals the difference between the current filter output and the desired response.

The direct-form LMS adaptive filter involves a long critical path due to an inner-product computation to obtain the filter output. It is modified to a form called thD delayed LMS (DLMS) algorithm, which allows pipelined implementation of the filter. The existing work on the DLMS adaptive filter does not discuss with the fixed-point implementation issues, such as the location of radix point, choice of word length, and quantization at various stages of computation. Therefore, fixed-point implementations in the proposed design reduce the number of pipeline delays along with the area, sampling period, and energy consumption. The proposed design is found to be more efficient in terms of the Power-Delay Product (PDP) and Energy-Delay Product (EDP) compared to the existing structures. The basic idea of an adaptive

<sup>1</sup> Nandha Engineering College, Erode.

noise cancellation algorithm is to pass the corrupted signal through a filter that tends to suppress the noise while leaving the signal unchanged. This is an adaptive process, which means it does not require a priori knowledge of signal or noise characteristics. Adaptive Noise Cancellation (ANC) efficiently attenuates low frequency noise for which passive methods are ineffective.

### ADAPTATION DELAY IN DLMS ADAPTIVE FILTER OVER CONVENTIONAL LMS ADAPTIVE FILTER

The block diagram of the DLMS adaptive filter is shown in Figure 1, shows the adaptation delay of  $m$  cycles amounts to the delay introduced by the whole of adaptive filter structure consisting of Finite Impulse Response (FIR) filtering and the weight-update process. The adaptation delay of conventional LMS can be decomposed into two parts: first part is the delay introduced by the pipeline stages in FIR filtering, and the other part is due to the delay involved in pipelining the weight update process. Based on such a decomposition of delay, the DLMS adaptive filter can be implemented by a structure shown in Figure 2.

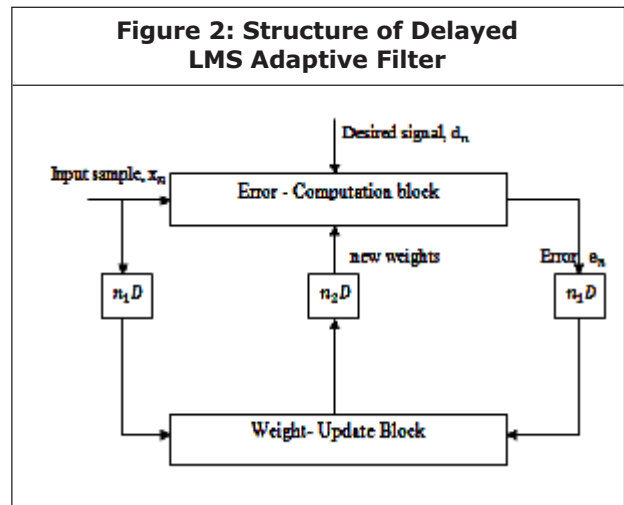
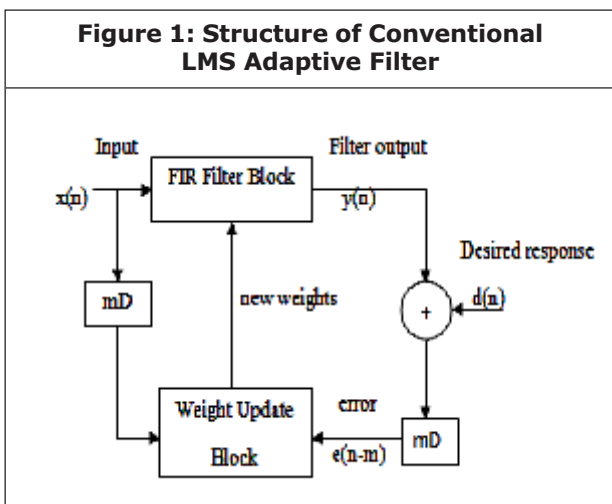

The modified DLMS algorithm decouples the error-computation block and the weight-update block and allows performing optimal pipelining by feed forward cut-set retiming to minimize the number of pipeline stages and adaptation delay.

The adaptation delay gets reduced in DLMS due to its pipelined structure, but in conventional structure of DLMS, the systolic architectures are used such that there exist a high adaptation delay.

### PIPELINED STRUCTURES OPTIMIZATION

#### A. Error-computation Block

The proposed structure for error-computation unit of an N-tap DLMS adaptive filter is shown in Figure 3. It consists of N number of 2-bit Partial

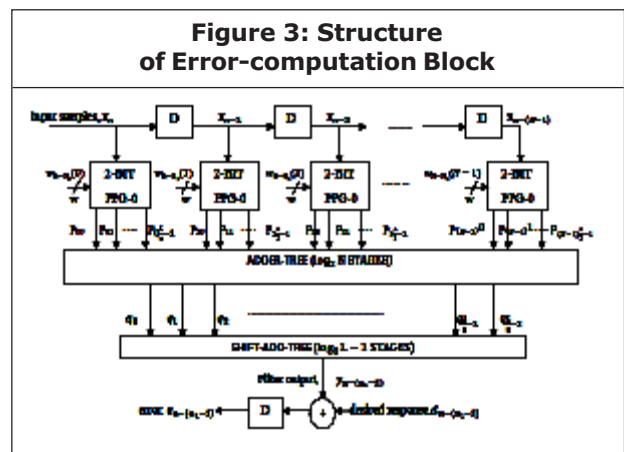

Product Generators (PPG) corresponding to N multipliers and a cluster of L/2 binary adder trees, followed by a single shift-add tree. Each sub block is described in detail.

**1) Structure of PPG:** The structure of each PPG is shown in Figure 4. It consists of L/2 number of 2-to-3 decoders and the equal number of AND/OR cells (AOC) Each of the 2-to-3 decoders takes a 2-bit digit ( $u_1u_0$ ) as input and produces three outputs. The decoder output  $b_0, b_1$  and  $b_2$  along with  $w, 2w,$  and  $3w$  are given to an AOC, where  $w, 2w,$  and  $3w$  are in 2's complement representation and sign-extended to have  $(W + 2)$  bits each.

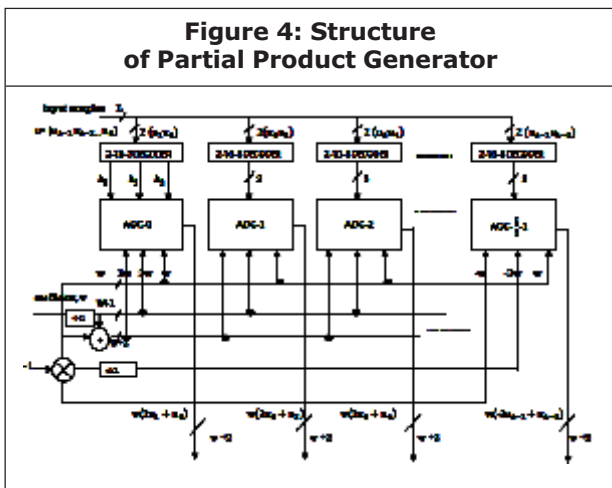

**2) Structure of AOCs:** The structures of an AOC consists three AND cells and two OR cells. Each AND cell takes n-bit input and a single bit input  $b,$  also consists of n gates. It distributes all the n bits of input D to its n AND as one of the inputs. The other inputs of all the n AND are fed with the single-bit input  $b.$  The output of an AOC  $w, 2w,$  and  $3w$  corresponding to the decimal values 1, 2, and 3 of the 2-b input ( $u_1u_0$ ). The decoder along with the AOC performs 2-bit multiplication and L/2 parallel multiplications with a 2-bit digit to produce L/2 partial products of the product word.

**3) Structure of Adder Tree:** The shifts-add operation on the partial products of each PPG gives the product value and then added all the N product values to compute the inner product output. However, the shift-add operation obtains the product value which increases the word length, and the adder size. To avoid increase in word size of the adders, we add all the N partial products of the same place value from all the N PPGs by a single adder tree.

**B. Weight-update Block**

The proposed structure of weight-update block is shown in Figure 5. It performs N multiply-accumulate operations of the form  $(\mu \times e) \times x_i + w_i$  to update N filter weights. The step size  $\mu$  is taken as a negative power of 2 to realize the multiplication with recently available error by the shift operation. Each MAC unit performs the multiplication of the shifted value of error with the delayed input samples  $x_i$  followed by the additions with the corresponding old weight values  $w_i.$  All the MAC operations are performed by N PPGs, followed by N shift-add trees. Each of the PPGs generates L/2 partial products corresponding to the product of the recently shifted error value  $\mu \times e$  with the number of 2-bit digits of the input word  $x_i.$  The sub expression can be shared across all

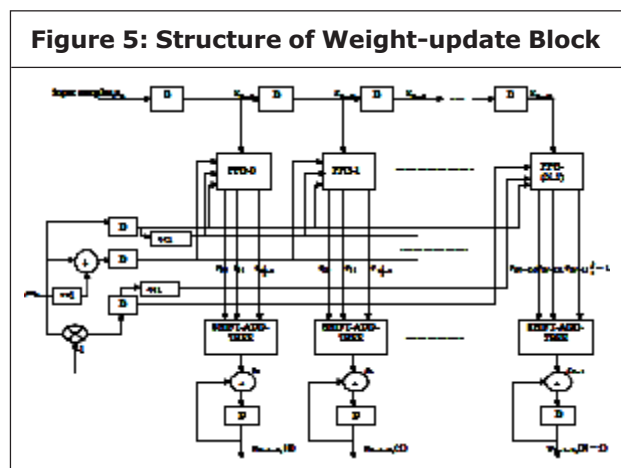

the multipliers. This leads to a gradual reduction adder in complexity. The final outputs of MAC units constitute updated weights to be used as inputs to the error-computation block and the weight-update block for the next iteration.

### ADDER TREE OPTIMIZATION

The adder tree and shift-add tree computation can be pruned for further optimization of area, delay, and power complexity. The adder tree structure is given in Figure 6.

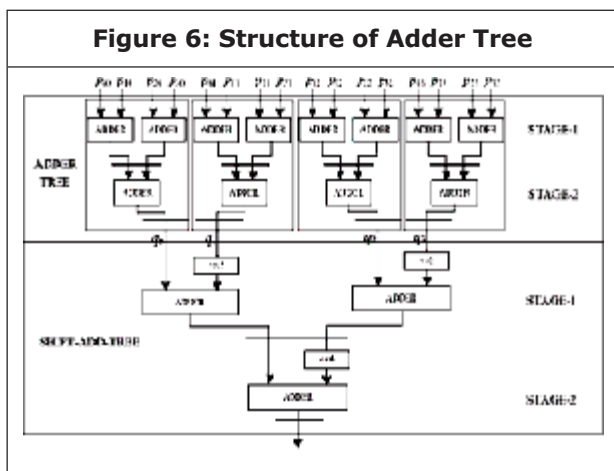

To reduce the computational complexity, some of the LSBs of inputs of the adder tree can be truncated and the guard bits can be used to minimize the impact of truncation on the error performance of the adaptive filter. To have more hardware saving, the bits to be truncated are not generated by the PPGs, so the complexity of PPGs also gets reduced. To have more hardware saving, the bits to be truncated are not generated by the PPGs, so the complexity of PPGs also gets reduced.

### LMS ADAPTIVE FILTER

LMS adaptive filter is used world wide because of its easy computation and flexibility. This algorithm is a member of stochastic gradient algorithm , and because of its robustness and

low computational complexity it is used worldwide. The algorithm using the steepest distance is as given below.

$$W(n+1) = w(n) - \mu \Delta J(W(n)) \quad \dots(1)$$

where

$$\Delta J(W(n)) = -2pdx + 2Rxw(n) \quad \dots(2)$$

Rx and pdx are the instantaneous estimates

Substituting Equation (1) and (2) in the above equation we get

$$W(n+1) = w(n) + 2\mu e(n)x(n) \quad \dots(3)$$

where

$$Y(n) = w_n^T x(n) \quad \dots(4)$$

$$E(n) = d(n) - y(n) \quad \dots(5)$$

The above two equations are required output of LMS algorithm where y (n) is the filter output and e (n) is the error. If the values of d (n) and y (n) will become equal we will get zero error. This filter could be used in combination of various other applications but our main focus is on noise cancellation.. Various applications are also there, which are already discussed above can also be analyzed using LMS filter. In this paper noise cancellation is achieved by LMS algorithm, i.e., step size. LMS adaptive filter also deals with the problem of Adaptive Noise Cancellation (ANC).

### APPLICATION OF LMS ALGORITHM IN ANC SYSTEM

As the name implies, ANC is a technique used to remove an unwanted noise from a received signal, the operation is controlled in an adaptive way in order to obtain an improved Signal to Noise Ratio (SNR). As shown in Figure 8 an ANC is typically a dual-input, closed loop adaptive feedback system. The two inputs are the primary input and

the reference signal. the adaptive filtering operation achieved the best results when the system output is noise free, which means that the output SNR is infinitely large. ANC technique has been widely used in many applications such as acoustic noise reduction, adaptive speech enhancement and channel equalization. Noise cancellation is a scheme of figuring out signals corrupted by additive noise or interference. From the Figure 7 given below it is clear that this system is comprised of primary as well as reference input. Input to the primary one is Signal source and indirectly noise source as well, Input to the reference one is Noise source.

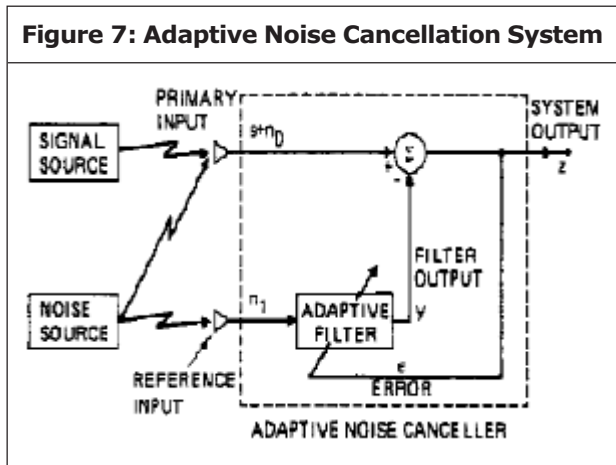

Figure 7: Adaptive Noise Cancellation System

The output (z) can be analyzed which is a combination signal and noise with adaptive filter. This can be analyzed from the following equations.

$$z = s + n_0 - y \quad \dots(6)$$

Squaring both the side we get

$$z^2 = s^2 + (n_0 - y)^2 + 2s(n_0 - y) \quad \dots(7)$$

Taking expectations (7) of both sides and realizing that s is uncorrelated with n0 and with y, yields

$$E[z^2] = E[s^2] + E[(n_0 - y)^2] + E[s(n_0 - y)] \dots(8)$$

$$= E[s^2] + E[(n_0 - y)^2]$$

The signal power  $E[s^2]$  will be unaffected as the filter is adjusted to minimize  $E[z^2]$ . Accordingly, the minimum output power is

$$\min E[z^2] = E[s^2] + \min E[(n_0 - y)^2] \quad \dots(9)$$

Thus when the filter is adjusted so that  $E[z^2]$  is minimized,  $E[(n_0 - y)^2]$  is, therefore, also minimized. The filter output y is then a best least squares estimate of the primary noise n0. Moreover, when is minimized, is also minimized. Therefore

$$(z - s) = (n_0 - y) \quad \dots(10)$$

Adjusting or adapting the filter to minimize the total output power is thus tantamount to causing the output z to be a best least squares estimate of the signal s for the given structure and adjustability of the adaptive filter and for the given reference input. The output z will contain the signal s plus noise. The output noise is given by  $(n_0 - y)$ . Since minimizing minimizes minimizing the total output power minimizes the output noise power. Since the signal in the output remains constant, minimizing the total output power maximizes the output signal-to-noise ratio. Minimizing the output power causes the output signal to be perfectly noise free.

## RESULT ANALYSIS

### Simulation Result of LMS Adaptive Filter

This section evaluates the performance of the proposed modified Least Mean Square (LMS) algorithm and Figure 8 shows the simulation results. And the result declares about the output of LMS adaptive filter without delay. After the clock input has given the output of the adaptive filter is achieved without delay. The Model SIM is the tool used here to check the performance of LMS adaptive filter.

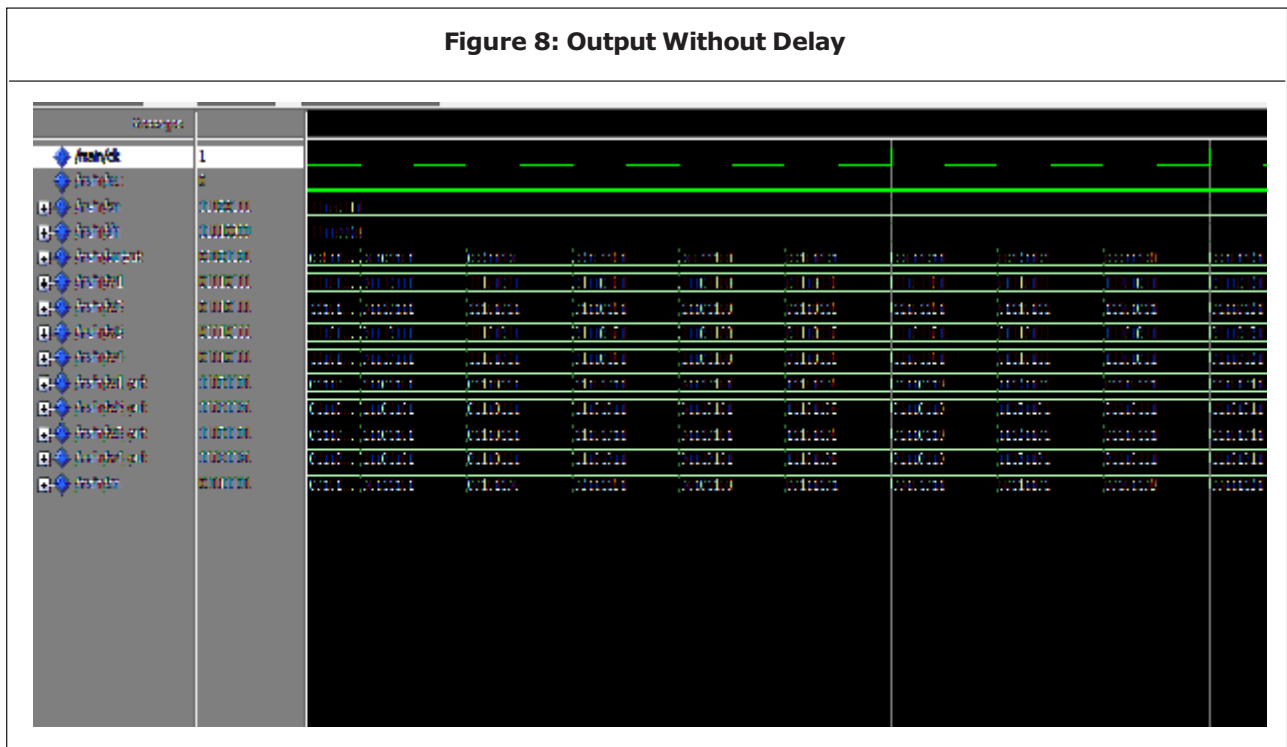

**Analysis of ADP and PDP**

The area, power and the timing report of conventional delayed LMS adaptive filter and

proposed delayed LMS adaptive filter is obtained using XILINX ISE simulator and it is shown in Table 1.

**Table 1: Comparision Between Existing and Proposed DLMS Algorithm**

Serial No.	ANALYSIS	AREA(gate counts)	POWER CONSUMPTION(mW)	MAX CLOCK DELAY (ns)	ADP	PDP
1	Conventional DLMS adaptive filter	8670	13	0.71	6155.7	9.23
2	Proposed DLMS adaptive filter	5456	11	0.69	3764.6	7.59

## SIMULATION RESULT OF ADAPTIVE NOISE CANCELLATION SYSTEM

The noise cancellation system using LMS Algorithm is simulated using MATLAB. Figure 9 below shows the simulation results and various waveforms of associated signals. The first waveform shows the voice. Second waveform shows the noise generated. Again the same signal is mixed with random noise which is shown in third waveform. After applying LMS algorithm the resultant signal is produced which is close to the original signal.

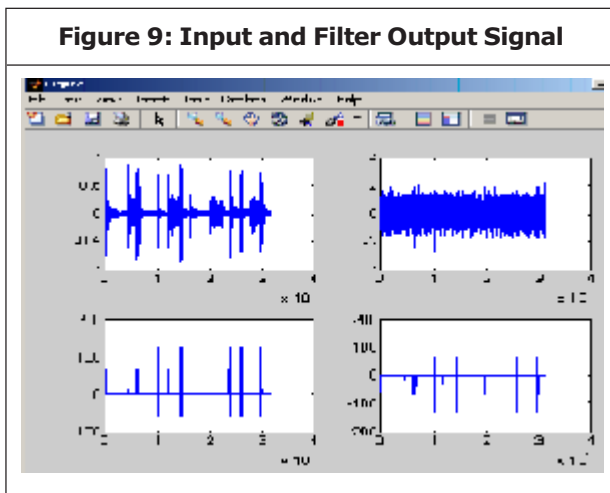

## CONCLUSION

An area-delay-power efficient with low adaptation-delay architecture for fixed-point implementation of DLMS adaptive filter are achieved by using a novel PPG for efficient implementation of general multiplications and inner-product computation by common sub expression. From this, proposed strategy an optimized balanced pipelining across the time-consuming blocks is to reduce the adaptation delay and power consumption. The proposed structure involved significantly less adaptation delay and provided significant saving of ADP and EDP compared to the existing

structures. And also The LMS algorithm for ANC system has been shown to produce good results in a noise cancellation problem.

## REFERENCES

1. Haykin S and Widrow B (2003), "Least-Mean-Square Adaptive Filters", Hoboken, NJ, USA: Wiley.
2. Herzberg H and Haimi-Cohen R (1992), "A systolic array realization of an LMS adaptive filter and the effects of delayed adaptation," *IEEE Trans. Signal Process.*, Vol. 40, No. 11, pp. 2799–2803.
3. Long G, Ling F and Proakis J G (1989), "The LMS Algorithm with Delayed Coefficient Adaptation," *IEEE Trans. Acoust. Speech, Signal Process*, Vol. 37, No. 9, pp. 1397–1405.
4. Mamta M Mahajan and Godbole S S (2011), "Design Of Least Mean Square Algorithm For Adaptive Noise Canceller", *International Journal Of Advanced Engineering Science And Technologies*, Vol. No. 5.
5. Meher P K and Maheshwari M (2011), "A high-speed FIR Adaptive filter architecture using a modified delayed LMS algorithm," *in Proc. IEEE Int. Symp. Circuits Syst*, pp. 121–124.
6. Pramod Kumar Meher (2014), "Area Delay Power Efficient Fixed Point LMS Adaptive Filter", Senior Member, IEEE and Sang Yoon Park, member, *IEEE transactions on very large scale integration (vlsi) systems*, Vol. 22, No. 2,
7. Van L D and Feng W S (2001), "An efficient systolic architecture for the DLMS adaptive filter and its applications," *IEEE Trans.*



*Circuits Syst. II, Analog Digital Signal Process.*, Vol. 48, No. 4, pp. 359–366.

8. Widrow B *et al.* (1975), “Adaptive Noise Cancelling: Principles and Applications”, *Proc. IEEE*, Vol. 63, pp.1692-1716.
9. Yi Y, Woods R, Ting L, and Cowan C F N (2005), “High Speed FPGA-based implementations of delayed- LMS filters,” *J. Very Large Scale Integr. (VLSI) Signal Process.*, Vol. 39, Nos. 1-2, pp. 113-131.
10. Ying He, Hong He, LiLi, YiWu and Hongyan Pan (2008), “The Applications and Simulation of Adaptive Filter in Noise Cancelling”, *International conference on computer Science and Software Engineering-2008*.



**International Journal of Engineering Research and Science & Technology**

**Hyderabad, INDIA. Ph: +91-09441351700, 09059645577**

**E-mail: editorijerst@gmail.com or editor@ijerst.com**

**Website: www.ijerst.com**

